

Ambient Ventline Heater

The Crane Cryogenics™ Ambient Ventline Heater (AVH) is specifically designed to eliminate the need for insulation on system ventline piping. The AVH warms the keepfull discharge gases to nearly ambient temperature which eliminates safety hazards as well as saves you time and money on ventline installation and material. The female bayonet on the AVH mounts directly to the outlet of the Crane Cryogenics™ Keepfull Vent Device.

Features:

- Various bayonet connection/sizes available.
- Replaceable Incoloy® heater element.
- Temperature controller and separate High/Low limit controller.
- Heater failure/low temperature indicator.

Benefits:

- Frost-free warmed discharge gas.
- Eliminates safety hazards such as falling objects, slips, trips and falls, and electrical hazards associated with ice buildup or moisture dripping from cold ventlines.
- Eliminates mold growth or T-bar ceiling damage associated with moisture or ice from cold ventlines.

Technical Specifications:

Service/MAWP	○	Liquid Nitrogen (LN2) / 150 psig (10.3 bar) Max
Standard Cable Lengths	○	Heater to Controller: 12 ft (3.66 m), optional 20 ft (6.01 m) Controller Power Cord (only on 120V 1500 Watt): 6 ft (1.83 m)
Vacuum Insulation	○	AVH Body: Static Vacuum Design
Materials	○	AVH Body: 304 / 304L Stainless Steel Heater Element Sheath: Incoloy® Heater Element Housing & NPT: 304 / 304L Stainless Steel Electrical Enclosure
Codes and Certifications	○	AVH Body: Built to ASME B31.3 Electrical Enclosures: NEMA 4X Heater Element Housing: NEMA 4
Controller Set Points	○	Set: 65° F (18° C) High Limit: 400° F (204° C) Low Limit: -60° F (-51° C)



Additional Keepfull Ventline Options:

- Low Temperature Cut Off (LTCO) with controlled downstream valve.
- Vacuum Insulated Vent Line (Typically vents to roof or outside wall).
- Standard Vent Heater is available for outdoor venting or termination in a large enclosed area with proper air exchange.
- Bayonet to copper adapter (Allows connection for copper vent piping with mechanical insulation).



Temperature Controller

Ordering Information:

Part Number	Bayonet Inlet Size Inches (DN)	Voltage VAC	Wattage	Amperage	Dim A Inches (mm)	Dim B Inches (mm)
CA00615	5/8" OD	120 w/NEMA 5-15 plug	1500	15	9 3/4" (247)	17 3/4" (451)
CA00625		120 w/o plug	3000	30		28 3/4" (730)
CA00616		220 w/o plug	1500	10		17 3/4" (451)
CA00626			3000	20		28 3/4" (730)
CA00610	1/2" NPS (15)	120 w/NEMA 5-15 plug	1500	15	11 1/2" (292)	17 3/4" (451)
CA00620		120 w/o plug	3000	30		28 3/4" (730)
CA00611		220 w/o plug	1500	10		17 3/4" (451)
CA00621			3000	20		28 3/4" (730)

Diagram:

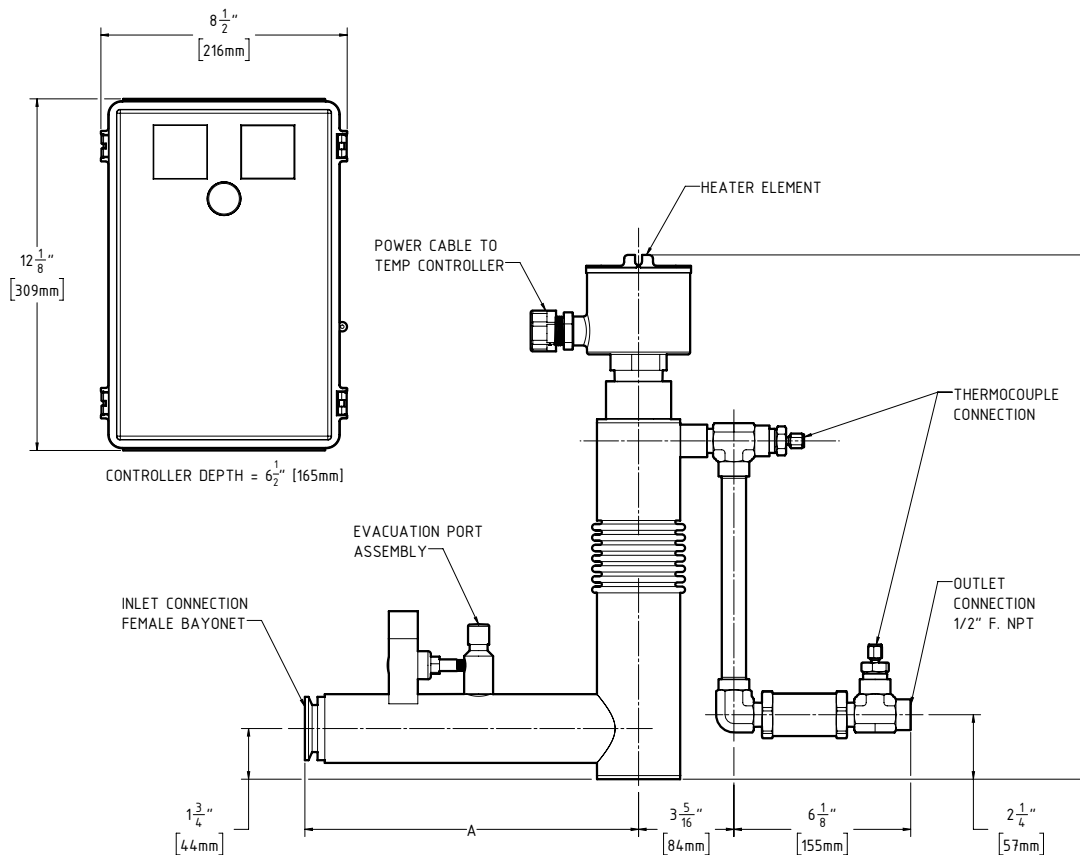

Installation Notes:

1. See AVH Owner's Manual for installation and operation details.
2. Check local codes prior to installation.
3. Outdoor or harsh environment installations should have suitable electrical connections.
4. Local on/off disconnect switches should be considered on roof or similar accessible areas to ease element replacement.
5. Terminate vents outdoors or in a safe area with adequate air exchange to ensure compliance with OSHA required oxygen safety standards. Oxygen monitors are critical safeguards to ensure oxygen levels in the work environment remain within safe limits.