

CryoLinks® Vacuum Insulated Pipe (VIP) is the preferred method for transporting cryogenic liquids and is unmatched in ease of installation, lead times, and cost-effectiveness compared to other mechanical insulated systems. We designed CryoLinks for high-pressure applications of 500 psi and higher.

Crane Cryogenics™ uses stainless steel inner and outer rigid tube/pipe in the manufacturing of our CryoLinks VIP Systems. The piping consists of a factory-fabricated inner line and outer jacket. The inner line carries the cryogenic fluid, while a vacuum space between the inner and outer pipe provides insulation that minimizes heat transfer and boil-off gas (BOG). The vacuum annular space consists of a multi-layer superinsulation, internal gettering material, and high vacuum.



## Features:

- Standard line sizes range from ½" OD tube to 4" NPS pipe.
- External expansion joints.
- Great alternative to foam-insulated copper.
- Higher rated pressures compared to conventional vacuum-insulated piping.
- End connections can be field welded or assembled with tube compression-type fittings.
  - No welding or brazing is required when using the Tube compression type fitting.
- Ideal for LN2 and LCO2 Applications.
- Fabricated to ASME B31.3.
- Joints can be easily mechanically insulated.
- Vacuum insulated flex sections available for system offsets, thermal expansion, expansion loops, flexibility, and use-point transitions.



Scan to view our current stock of CryoLinks® on Shop.CryoWorks.Net

## Benefits:

- Approximately 50 times more effective than conventional foam insulation in preventing heat gain to the inner line and nearly 200 times more effective than bare copper lines.
- Pre-engineered lengths and fittings reduce lead time and cost.
- Extremely long-lasting and impervious to UV degradation.
- Minimize space required for routing.
- Minimize cool-down losses.
- Minimize FOD (Foreign Object Debris).



Tube Compression Fitting End Example

## Available Accessories/Options:

- Safety/Thermal Relief Assemblies
- Keepfulls/High Point Vents
- Vent Heaters
- Vacuum Insulated Transfer Hoses
- Emergency Shut Off Valves
- Isolation Valves
- Custom Weldments/Adapters
- Tube Compression Fittings (½", 1", 1½", 2" OD)
- Insulation Kits (Coming Soon)
- Vacuum Insulated In-Line Valves
- Bronze CryoValves
- Internal Low Loss Gas Traps
- ASME Code Compliant Testing and Certification



CryoLinks® Compression Fitting (Tube Only)



CryoLinks® Welded Connection (Tube or Pipe)

## Tube Size - Technical Data

| Tube Line Size | Internal Diameter | Outer Diameter | Heat Leak BTU/hr*ft (W/m) |               | MAWP psi | Weight lbs/ft |
|----------------|-------------------|----------------|---------------------------|---------------|----------|---------------|
|                |                   |                | LN2                       | LC02          |          |               |
| ½" OD          | 0.5"              | 1½" OD         | 0.158 (0.273)             | 0.073 (0.126) | 1176     | 1.180         |
| 1" OD          | 1"                | 2" NPS         | 0.273 (0.417)             | 0.126 (0.217) | 978      | 1.858         |
| 1½" OD         | 1.5"              | 2½" NPS        | 0.386 (0.668)             | 0.178 (0.308) | 569      | 2.472         |
| 2" OD          | 2"                | 3" NPS         | 0.499 (0.864)             | 0.230 (0.398) | 551      | 3.088         |

OD = Outer Diameter, NPS = Nominal Pipe Size, Multi-Layer Insulation (MLI) = 20

## LN2 Tube Flow Data (Maximum recommended Flow Rate)

| Tube Line Size | gpm  | lpm  | lbs/min |
|----------------|------|------|---------|
| ½" OD          | 1.60 | 6.06 | 10.8    |
| 1" OD          | 13.9 | 52.7 | 93.9    |
| 1½" OD         | 41.9 | 159  | 283     |
| 2" OD          | 95.1 | 360  | 641     |

\*\*Data Based on 100 Feet of Tubing and 5 Elbows while maintaining less than 5 psi friction pressure drop @ 75 psi operating pressure\*\*

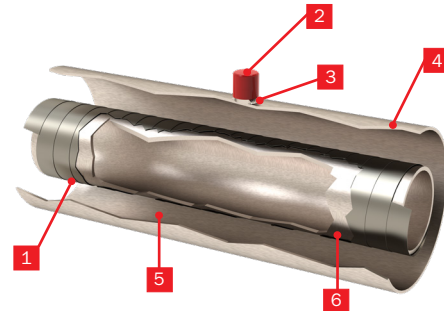

| Item | Description                   |
|------|-------------------------------|
| 1    | Multi-Layer Super Insulation  |
| 2    | Relief Port                   |
| 3    | Tig Welds                     |
| 4    | Stainless Steel Outer Pipe    |
| 5    | Static High Vacuum Insulation |
| 6    | Stainless Steel Inner Pipe    |

## Pipe Size - Technical Data

| Pipe Line Size | Internal Diameter | Outer Diameter | Heat Leak BTU/hr*ft (W/m) |               | MAWP psi | Weight lbs/ft |
|----------------|-------------------|----------------|---------------------------|---------------|----------|---------------|
|                |                   |                | LN2                       | LC02          |          |               |
| 1" NPS         | 1.31"             | 2" NPS         | 0.345 (0.597)             | 0.159 (0.275) | 1505     | 2.47          |
| 2" NPS         | 2.37"             | 3" NPS         | 0.586 (1.013)             | 0.270 (0.467) | 819      | 4.63          |
| 3" NPS         | 3.5"              | 4" NPS         | 0.841 (1.455)             | 0.388 (0.671) | 711      | 6.94          |
| 4" NPS         | 4.5"              | 5" NPS         | 1.068 (1.847)             | 0.492 (0.851) | 552      | 12.65         |

NPS = Nominal Pipe Size, Multi-Layer Insulation (MLI) = 20

## LN2 Pipe Flow Data (Maximum recommended Flow Rate)

| Pipe Line Size | gpm   | lpm     | lbs/min |
|----------------|-------|---------|---------|
| 1" NPS         | 28.6  | 108.26  | 192.93  |
| 2" NPS         | 153   | 579.16  | 1032.14 |
| 3" NPS         | 425.9 | 1612.21 | 2873.12 |
| 4" NPS         | 890   | 3369    | 6004.70 |

\*\*Data Based on 100 Feet of Piping and 5 Elbows while maintaining less than 5 psi friction pressure drop @ 75 psi operating pressure\*\*



**Each CryoLinks® VIP transfer line system is factory: fabricated, evacuated, tested, cleaned, and shipped in manageable spool sections.**

## Is It Time To Install a CryoLinks® System at Your Location?

CryoLinks® makes cryogenic handling more economical, efficient, and safe.

Many "types" of cryogenic fluid delivery systems exist, the trick is to find the one type that best suits your needs. The common progression, as a user's cryogenic fluid volume increases, goes from a simple single dewar and flex hose, to multiple dewars with switching units and rigid piping, all the way to multiple bulk tanks with a complex network of piping, valves, and drops, with many variations existing between the examples provided. Installing the correct type of system for your operation will optimize cost for both the cryogenic product and handling labor, as well as the safety of those handling the related equipment and fluids.

If you are dealing with the troubles of moving heavy dewars from location to location, work interruptions caused by late delivery and dewar swap out, rental fees, floor and wall damages, and all the countless associated safety risks, then it is time to upgrade your system to a type utilizing CryoLinks.



## System Schematic

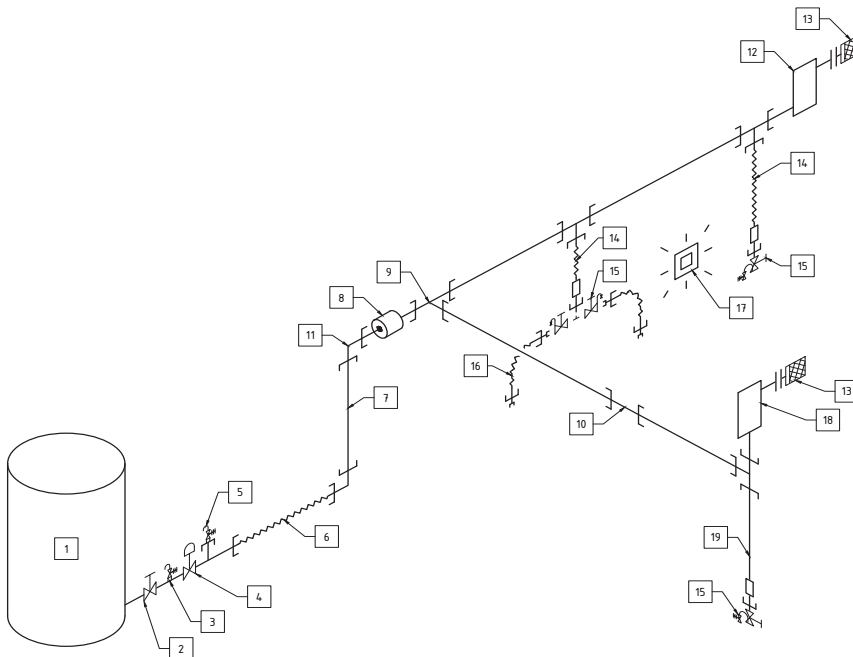

| Item | Description  |
|------|--|
| 1    | LN2 Bulk Tank                                      |
| 2    | Tank Withdrawal Valve                              |
| 3    | Safety Relief Valve (SRV)                          |
| 4    | Emergency Shut-Off Valve (E-Stop)                  |
| 5    | System Safety Relief Valve                         |
| 6    | Vacuum Insulated Flex Hose CryoLinks® Spool        |
| 7    | Vacuum Insulated Rigid CryoLinks® Spool            |
| 8    | Building Wall Penetration                          |
| 9    | Tee Joint Connection                               |
| 10   | Straight Joint Connection                          |
| 11   | Elbow Joint Connection                             |
| 12   | CryoLinks® End of Line (EOL) Keepfull Device       |
| 13   | Vent Heater  |
| 14   | Vacuum Insulated Flex Hose                         |
| 15   | Bronze CryoValve w/Integral SRV                    |
| 16   | Vacuum Insulated Transfer Hose                     |
| 17   | Oxygen Deficiency Monitor                          |
| 18   | CryoLinks® Vertical Keepfull Device                |
| 19   | Vacuum Insulated Rigid CryoLinks® Spool w/Gas Trap |