

Rigid Vacuum Insulated Pipe (RVIP)

Crane Cryogenics™ uses stainless steel inner and outer pipe in the manufacturing of our Rigid Vacuum Insulated Pipe (RVIP) systems. The piping consists of a factory-fabricated inner line and outer jacket. The inner line carries the cryogenic fluid, while a vacuum space between the inner and outer pipe provides insulation that minimizes heat transfer and boil-off gas (BOG). The vacuum annular space consists of multi-layer super insulation, internal gettering material, and high vacuum insulation. Standard sizes of our Rigid VIP Systems include ½” to 16” NPS with either internal or external expansion joints.

Features:

- Ideal for LN2 and other cryogenic applications.
- Bayonet connections with no field welding required.
- Standard system components: tees, crosses, elbows, valves, keepfull vents, and gas traps.
- Integrated flex sections added for system offsets, thermal expansion, expansion loops, and as flexible take-offs to equipment drops and use points.
- Each spool section is helium leak tested, evacuated, and vacuum sealed prior to shipment.
- No on-site vacuum pumps required - factory evacuated and sealed.



Benefits:

- Easy to install - the lightweight, compact jacket size, facilitates even the toughest installations.
- Crane Cryogenics™ bayonets utilized for ease of installation, no field welding required.
- Need something quick? We stock bundles of raw pipe material.
- Alternative to foam insulated copper.
- Approximately 50 times more effective than conventional foam insulation in preventing heat gain to the inner line and nearly 200 times more effective than bare copper lines.
- Extremely long-lasting and impervious to UV degradation.
- Superior vacuum insulation minimizes vaporization, reduces operating costs, and provides controllable quality liquid when and where you need it.
- Less mass - the thin wall inner material allows for a quicker cool down time while minimizing start-up losses.
- Cost-effective shipping: Systems can be shipped in wooden crates or by flatbed truck.

Available Accessories/Options:

- Keepfulls/High Point Vents
- Vent Heaters
- Vacuum Insulated Valves
- Emergency Shut Off Valves
- Isolation Valves
- Bronze Cryo-Valves
- Phase Separators
- Internal Low Loss Gas Traps
- Safety Relief Valves
- Custom Weldments/Adapters
- Vacuum Gauge Tubes (DV-6R or DV-6S)
- Vacuum Insulated Transfer Hoses (Connection to equipment)
- ASME Code Compliant Testing and Certification



Bayonet Connection



Vacuum Insulated Field Joint

RVIP Technical Specifications:

Inner Pipe NPS (DN)	Outer Pipe NPS (DN)	Pipe Wall Schedule (Inner/Jacket)	Jacket OD Nominal Inch (mm)	Dry Weight		MAWP - Internal Expansion Joints			MAWP - External Expansion Joints		
						Bayonet	Bayonet	Field Joint	Bayonet	Bayonet	Field Joint
				lbs/ft	kg/m	CT or Invar	F-Series	Welded	CT or Invar	F-Series	Welded
½" (15)	2" (50)	5/5	2.375 (60.33)	3.00	4.46	150	275	350	150	275	2388
1" (25)	3" (80)	5/5	3.500 (88.90)	4.48	6.67	150	275	350	150	275	1505
1 ½" (40)	3 ½" (90)	5/5	4.000 (101.60)	5.46	8.12	150	150	150	150	275	1034
2" (50)	4" (100)	5/5	4.500 (114.30)	6.07	9.03	150	150	150	150	275	819
3" (80)	5" (125)	5/5	5.563 (141.30)	10.32	15.35	See Eng	150	150	See Eng	275	711
4" (100)	6" (150)	5/5	6.625 (168.28)	12.65	18.83	See Eng	150	150	See Eng	275	552
6" (150)	8" (200)	10s/10s	8.625 (219.08)	24.96	37.14	See Eng	See Eng	See Eng	See Eng	275	604
8" (200)	10" (250)	10s/10s	10.750 (273.05)	35.31	52.55	See Eng	See Eng	See Eng	See Eng	275	512
10" (250)	12" (300)	10s/10s	12.750 (323.85)	47.15	70.16	See Eng	See Eng	See Eng	See Eng	See Eng	457
12" (300)	16" (450)	10s/10s	16.000 (406.40)	61.50	91.52	See Eng	See Eng	See Eng	See Eng	See Eng	421

OD = Outer Diameter, MAWP = Maximum Allowable Working Pressure, CT = Close Tolerance, Invar = Dissimilar Metal, F-Series = Flange Series.

RVIP Heat Leak - Btu/hr*ft (Watts per meter):

Line Size	LNG -265°F	LOX -297°F	LN2 -320°F	LH2 -423°F	LHe -452°F
	20 MLI Layers				24 MLI Layers
½" (15)	0.199 (0.19)	0.222 (0.21)	0.236 (0.23)	0.298 (0.29)	0.272 (0.26)
1" (25)	0.290 (0.28)	0.324 (0.31)	0.344 (0.33)	0.434 (0.42)	0.394 (0.38)
1 ½" (40)	0.375 (0.36)	0.419 (0.40)	0.445 (0.43)	0.562 (0.54)	0.507 (0.49)
2" (50)	0.490 (0.47)	0.547 (0.53)	0.581 (0.56)	0.734 (0.71)	0.659 (0.63)
3" (80)	0.704 (0.68)	0.785 (0.75)	0.834 (0.80)	1.053 (1.01)	0.942 (0.91)
4" (100)	0.892 (0.86)	0.996 (0.96)	1.058 (1.01)	1.336 (1.28)	1.192 (1.15)
6" (150)	1.296 (1.25)	1.446 (1.39)	1.537 (1.48)	1.940 (1.87)	1.727 (1.66)
8" (200)	1.673 (1.61)	1.867 (1.80)	1.984 (1.91)	2.504 (2.41)	2.226 (2.14)
10" (250)	2.078 (2.00)	2.319 (2.23)	2.464 (2.37)	3.110 (3.00)	2.762 (2.66)
12" (300)	2.431 (2.34)	2.714 (2.61)	2.884 (2.77)	3.640 (3.50)	3.236 (3.11)

Data is provided for estimation only. Contact CryoWorks for a thorough system analysis.
Data based on straight pipe only (no internal spacers, fittings, or bayonets).
For system estimates with average components, increase per foot data by 20%.

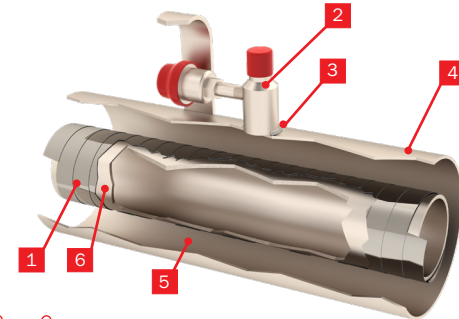

Item	Description
1	Multi-Layer Super Insulation
2	Combination Evacuation/Relief Port w/Optional TC Vacuum Gauge Tube
3	Tig Welds
4	Stainless Steel Outer Pipe
5	Static High Vacuum Insulation
6	Stainless Steel Inner Pipe

RVIP Flow Rate:

Line Size	gpm	lpm	lbs/min
½" (15)	7.66	29	51.7
1" (25)	29.6	112	199.7
1 ½" (40)	85.2	323	574.8
2" (50)	159	602	1,072.8
3" (80)	441	1,669	2,975.4
4" (100)	890	3,369	6,004.7
6" (150)	2,417	9,149	16,307.2
8" (200)	4,883	18,484	32,945.0
10" (250)	8,740	33,084	58,967.7
12" (300)	13,700	51,860	92,432.2

Data based on:

1. Maximum recommended flow rate.
2. 100 feet of rigid piping while maintaining less than 5 psi friction pressure drop @ 60 psi operating pressure.

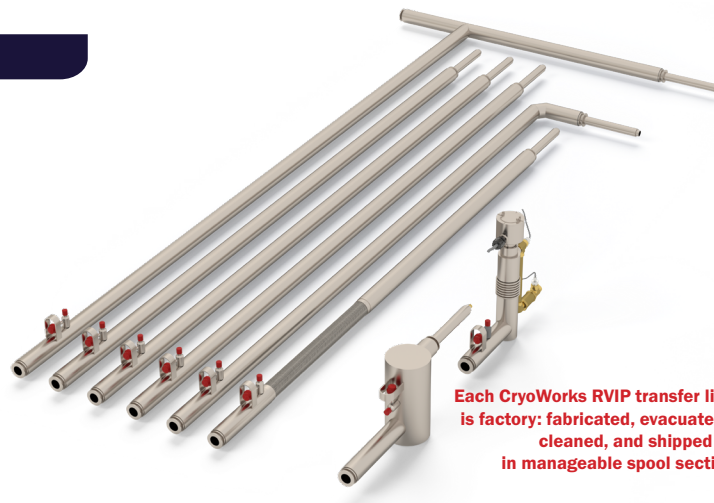

Each CryoWorks RVIP transfer line system is factory: fabricated, evacuated, tested, cleaned, and shipped in manageable pool sections.

Is It Time To Install a Rigid VIP System at Your Location?

Crane Cryogenics™ RVIP makes cryogenic handling more economical, efficient, and safe.

Many "types" of cryogenic fluid delivery systems exist, the trick is to find the one type that best suits your needs. The common progression, as a user's cryogenic fluid volume increases, goes from a simple single dewar and flex hose, to multiple dewars with switching units and rigid piping, all the way to multiple bulk tanks with a complex network of piping, valves, and drops, with many variations existing between the examples provided. Installing the correct type of system for your operation will optimize cost for both the cryogenic product and handling labor, as well as the safety of those handling the related equipment and fluids.

If you are dealing with the troubles of moving heavy dewars from location to location, work interruptions caused by late delivery and dewar swap out, rental fees, floor and wall damages, and all the countless associated safety risks, then it is time to upgrade your system to a type utilizing RVIP.



System Schematic:

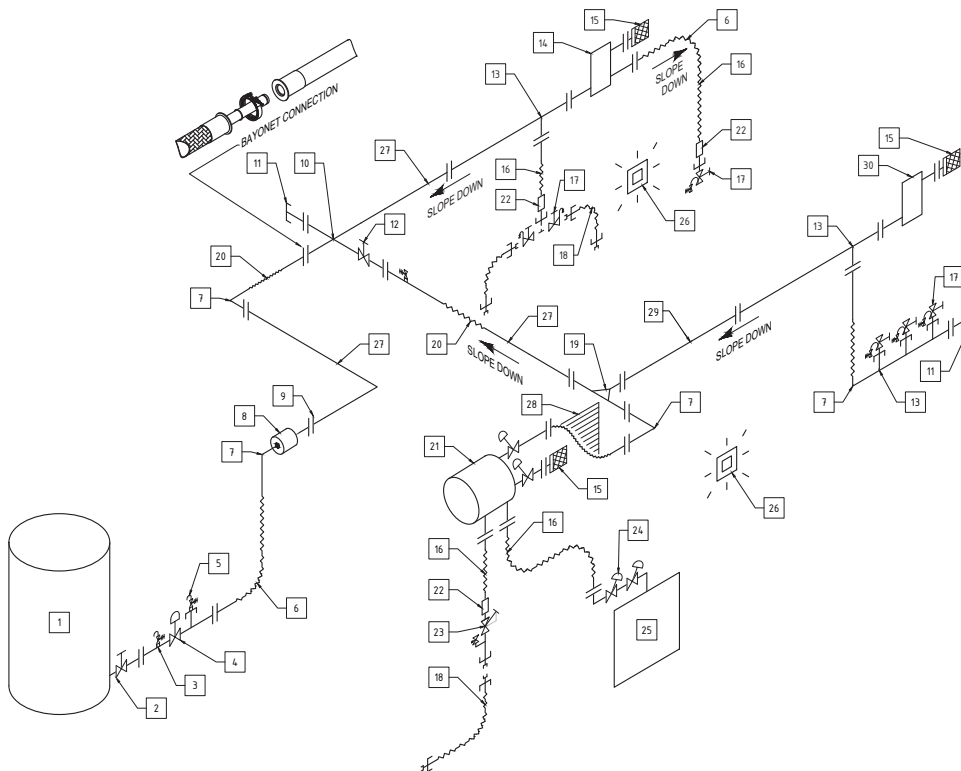

Item	Description
1	LN2 Bulk Tank
2	Vacuum Insulated Withdrawal Valve and Bayonet
3	Safety Relief Valve (SRV) on Pigtail Style Relief Port
4	Emergency Shut-Off Valve (E-Stop)
5	Safety Relief Valve (SRV) on Vacuum Insulated Riser
6	Vacuum Insulated Flex Elbow
7	Rigid Vacuum Insulated Elbow
8	Building Wall Penetration
9	Bayonet Connection (FxM)
10	Vacuum Insulated Cross
11	Capped Female Bayonet (Future Connection)
12	Vacuum Insulated Manual Valve (Globe w/SRV)
13	Rigid Vacuum Insulated Tee
14	Keepfull Vent Device, Inline (FxM)
15	Vent Heater
16	Flexible VIP Drop
17	Bronze CryoValve with Integral SRV
18	Vacuum Insulated Transfer Hose
19	Vacuum Insulated Reducing Tee
20	Vacuum Insulated Flex Section
21	Adjustable Pressure Phase Separator (2 Outlet)
22	Gas Trap with M. NPT End
23	Vacuum Insulated Manual Valve (Y-pattern w/SRV)
24	Vacuum Insulated Pneumatic Control Valve Manifold
25	Customer Equipment
26	Oxygen Deficiency Monitor
27	Rigid Vacuum Insulated Pipe
28	Vertical Flex Offset
29	Rigid Vacuum Insulated Pipe (Straight Stick)
30	Keepfull Vent Device, End of Line

Engineering & Design:

Project Management and Engineering go hand in hand. That's why CryoWorks strives to ensure excellent communication and seamless integration between the two. Engineering services for your project may include project reviews, intricate drawings, calculations, simulations, and much more. No matter the complexity of your project, our team is prepared to meet these demands. Operating at a level above our competition, we take pride in the exceptional quality of our designs, drawings, and documentation that convey exactly what you need.

Having our engineering team work closely with our skilled employees enables CryoWorks to maintain tight quality control over the manufacturing process. This allows us to tackle issues and obstacles quickly by making adjustments and changes as needed. Rest assured that during the project life cycle, your single point of contact, our Technical Sales engineers, will Make It Happen, Make It Easy, and Make It Fun!

What you can expect from CryoWorks is a skilled engineering team that designs safe, fully functional, and reliable systems.

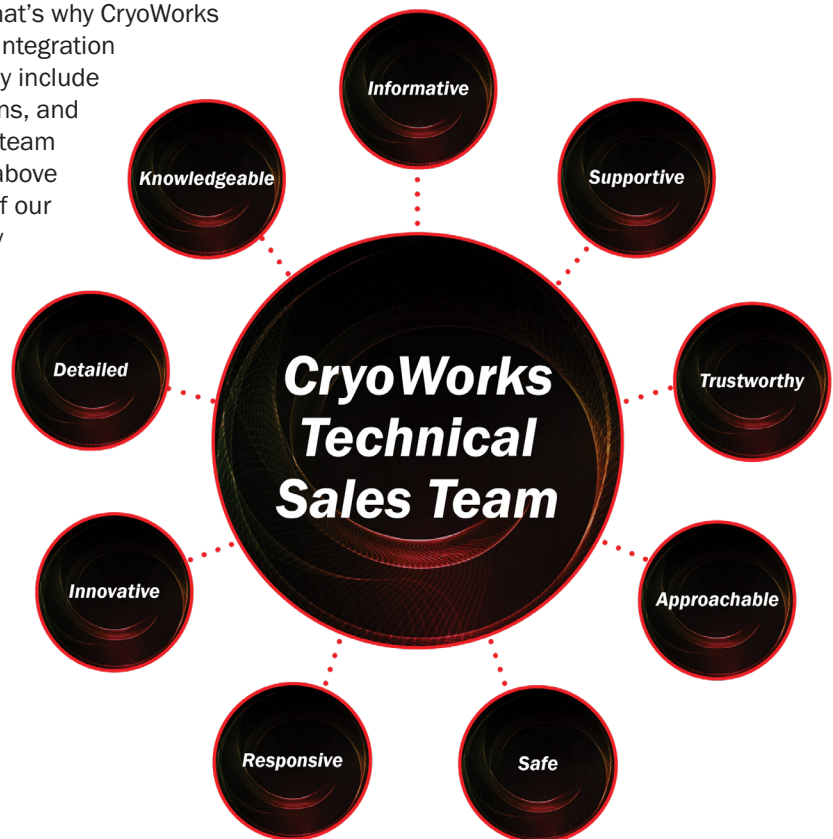

2D/3D Detailed Drawings:

We offer the following packages:

- Building Plan View Overlays
- BIM Overlay
- Isometrics
- Structural/Mechanical
- Installation Details
- Professional Engineer Stamped
- Custom Product Design

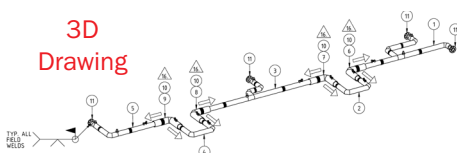
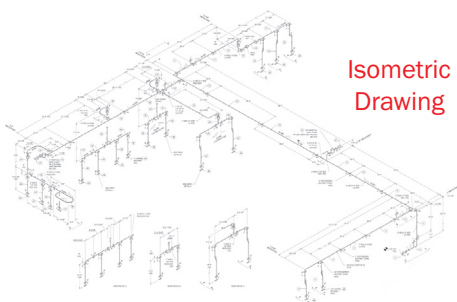

Added Options:

- MTR's
- 3rd Party Inspections
- Cold Shock Testing
- Radiographic Testing
- Liquid Penetrant Testing
- CWI Visual Testing
- Pressure Testing
- Flow Testing (Gaseous/Cryogenic)
- O2 Cleaning (CGA G-4.1, IEST-STD-1246E, etc.)
- Bright Brush/Polished Finishes
- Project Specific Requirements (Hold Points, Cleaning, Testing, Code, etc.)



Engineering Analysis:

- Internal Pressure
- External Loads
- Pipe Stress Analysis
- Combined Loads
- Thermal Cycling
- Pressure Drop
- Heat Leak
- Finite Element Analysis (FEA)

